

EpiFaith[®] syringe

Epidural locating syringe with Faith Signal

SF0111E

INSTRUCTIONS FOR USE

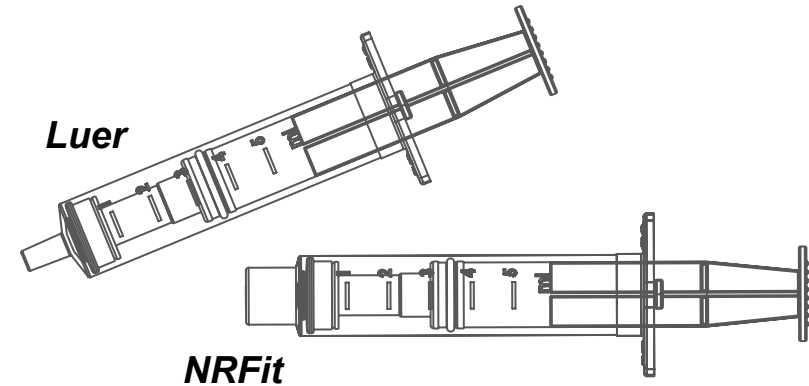

Caution



Consult instructions for use



Do Not Reuse



Do Not Resterilize



Batch Code



Use-by date



Manufacturer



Date of Manufacture



Sterilized using ethylene oxide



Do not use if package is damaged.



Keep away from sunlight



Storage temperature range



Requires prescription in the United States.



Catalogue number



Non-pyrogenic



Flat Medical Co., Ltd.
12F-2, No. 206, Sec. 2, Nanjing E. Rd.
Zhongshan Dist., Taipei City 104, Taiwan
Tel: +886 2 25672959

www.flatmedical.com



EpiFaith[®] syringe

Follow the instructions carefully.

INSTRUCTIONS FOR USE

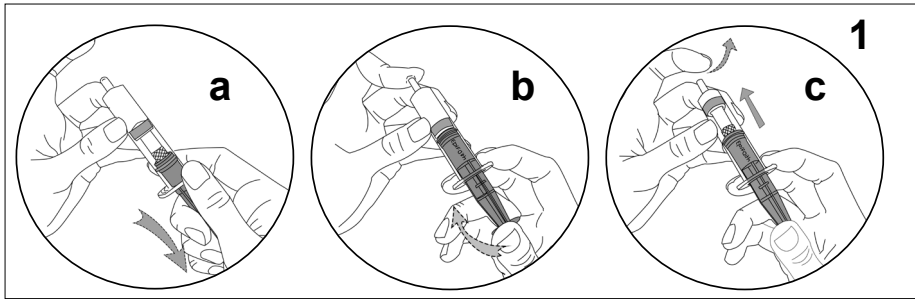

* The Luer version is used as the example for demonstration.

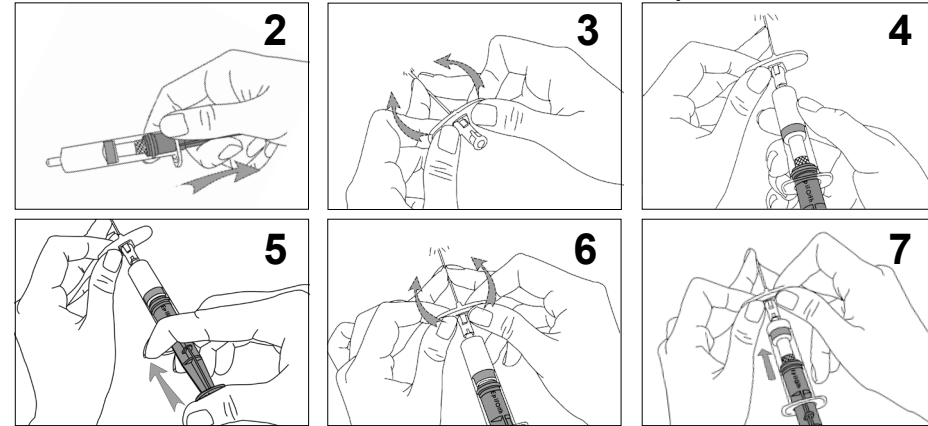

Indications for use

EpiFaith Syringe is intended for use with an epidural needle for detecting a loss of resistance, which aids a clinician in verifying needle tip placement in the epidural space.

Intended performance

This device has been shown to signal loss of pressure during simulated use testing. The loss of closed system pressure will trigger a warning signal, which is the movement of piston. This product is intended to serve as an aid to healthcare providers properly trained and experienced in a loss-of-resistance epidural placement, by visually indicating when an attached needle has entered the epidural space.

Contraindications and Restrictions on use

CAUTION

The product should only be used to aid the implementation of the loss of resistance technique and can only be used on patients that are suitable for the technique. This device must not be used unless the user has been adequately trained in the technique and is fully familiar with the user instructions, intended purpose, use, and intended performance of this device.

Absolute contraindications include patient refusal, severe uncorrected hypovolemia, increased intracranial pressure, infection at the site of injection and known hypersensitivity to local anesthetics. Relative contraindications include coagulation disorders, anticoagulant therapy, pre-existing neurological disease, fixed cardiac output states, uncooperative patients, spine abnormalities or surgeries, and sepsis.

Risks

EpiFaith syringe is based on the loss of resistance technique. Thus, there is a risk, as with all epidural procedures performed with the technique, that the performance of the device can be influenced by the patient's factor. The loss of resistance may not be obvious if the patient has abnormal pressure in the epidural space or spinal anatomical abnormalities.

Notice that a false signal may be given by the EpiFaith syringe if its contents leak into the tissues or if connections leak. Also, EpiFaith syringe may not give the warning signal if the needle is obstructed by tissue or blood.

Side effects

Side effects are limited to discomfort from subcutaneous bleeding and bruising from the needle entry point.

Warnings

Do not use if packaging is damaged.

Do not re-use the product. Re-use of a single use product may lead to contamination and/or impairment of functional capability.

Do not re-sterilize.

Do not use after the expiry of the use-by date, which is located on the unit/lot number label.

Do not withdraw the plunger out of the barrel, which may lead to contamination and/or impairment of functional capability.

The device is only made for the loss of resistance technique. Do not use the product to deliver any kind of medicine.

Preparation and Assembly

General

The procedure should be carried out under the strictest sterile protocol.

Familiarization

It is essential that users familiarize themselves with the features and performance characteristics of the device. Please study the device and the user instructions carefully and do not proceed with a procedure until fully satisfied that the instructions are understood.

Environment and Safety

The procedures should be carried out in an appropriate anesthetic environment, having all emergency equipment and materials available, to ensure that the patient is safe.

Associated Consumables

Use the product with state of the art epidural kits, which have Luer/ NRFit connections.

CAUTION: The EpiFaith syringes are only compatible with state of art 16-18G epidural needles with Luer / NRFit meeting the ISO80369-7/6 standard.

Directions

CAUTION: DO NOT ADVANCE THE NEEDLE IF COLOR RING IS NOT COVERED.

1 Function test: Manually occluding and releasing to check that the unit is functional. **CAUTION: The function of the EpiFaith syringe should be tested prior to use. Do not use the device and call the manufacturer if the function test fails.**

- Fill the device with air by pulling the plunger. (Fig. 1a)
- Use a sterile glove, occlude the exit port, and then push the plunger until the color ring is covered and keep the exit port occluded. If the color ring does not remain covered, then the function test has failed. (Fig. 1b)
- Release the exit port. The piston should move forward rapidly. (Fig. 1c)

2 Fill the EpiFaith syringe by withdrawing the plunger. (Fig. 2)

Note: EpiFaith syringe can be used with liquid or air.

3 Insert the needle through the tissue until it is situated in the appropriate region, such as the ligamentum flavum. (Fig. 3)

4 Remove the stylet and attach the filled EpiFaith syringe to the needle. (Fig. 4)

5 Push the plunger slowly to start the pressure sensing. The color ring should be covered before advancing the needle. (Fig. 5)

Note: Pushing the plunger to cover the color ring and piston, leads to an innerspring being compressed to induce the pressure for the LOR technique. The pressure is proportional to the covered level of the piston.

Note: Do not push the plunger if the piston shaft is entirely covered.

CAUTION: If the color ring cannot be covered after pushing the plunger, which implies a failure to build up pressure, consider whether the tip of the needle is already in the epidural space, in the sub-dural space or in the intrathecal space.

6 Advance the needle. (Fig. 6)

Note: This device can maintain the pressure automatically. Thus, it is not necessary to hold the plunger while advancing the needle. It is recommended that both hands be used to control the needle and avoid pushing the plunger unless the contents have leaked.

Note: Content leakage is possible if redirection of the needle is required. To avoid leakage, we recommend pulling the plunger until the color ring is exposed before redirection. After redirection, return to step 5 to complete the procedure.

7 Stop needle advancement if the piston moves forward or the color ring appears, which implies the loss of resistance occurs. (Fig. 7)

CAUTION: As all loss of resistance technique, the loss of closed system pressure and the appearance of warning signal will indicate only that the needle tip has entered a void or that the system is otherwise open; hence, the user must rely on her/his own experience and carefully to confirm the location of the needle tip even if the warning signal occurs.

Storage

Store at temperatures between 10 - 35 °C.

Keep away from sunlight.

Disposal

Follow local protocols in respect of the disposal of the equipment.

Failure to dispose of the device correctly could lead to serious infections.

If an incorrect method of disposal is employed, the outcome may be harmful to a third party or to the environment.